

LEADER Connector Installation Manual

Connector 安装手册

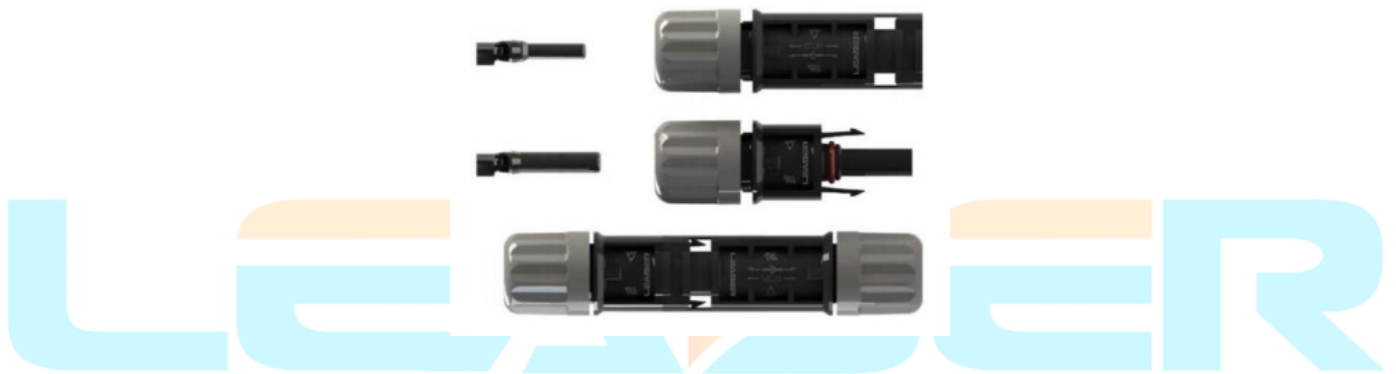

文件编号 File No: LEADER- A

版本 Version: 2021 V5

日期 Date: 2021.06.16

Remark1: The connector is considered to be in compliance with UL 6703 only when assembled in the manner specified by these assembly instructions"

Remark2: This connector is suitable for use only with Class B and C stranded copper conductors (See NFPA NEC 70 Chapter 9, Table 10)



1. 警告 Warning

1) 为防止电击，在安装和拆卸连接器时必须断开电源。

In order to protect against electric shock, please shut down the power when assembling and disassembling the PV connectors.

2) 终端产品必须提供防电击功能。

The final products must be supplied with the function electric shock proof.

3) 不要在负载下断开：在有负载的情况下，不能拔出 PV 插头连接器！关掉 DC/AC 直流-交流变频器或打开 DC 交流电路断路器，使 PV 接头连接器处于无负载的状态，则允许插拔。

Do not disconnect under Load: PV plug connections must not be disconnected while under load. They can be placed in a no load state by switching off the DC/AC converter or breaking the AC circuit.

4) 该连接器仅适用于 B 类和 C 类多股铜导线（见 NFPA NEC 70 第 9 章，表 10）。建议使用光伏专用线缆，镀锡铜芯，双层绝缘，绝缘材料为 XLPE。不建议使用无镀锡电缆，不建议使用 PVC 电缆。This connector is suitable for use only with Class B and C stranded copper conductors (See NFPA NEC 70 Chapter 9, Table 10). The use of PV cable is recommended, Tinned copper wire, Double insulation, Insulating material: XLPE. Tin free cable is not recommended. PVC cable is not recommended.

5) 断开的连接器必须使用防尘塞，

6) 以防止灰尘和水进入。被污染的连接不能插合。

Sealing cap must be used for disconnected connector, avoiding dust and water. The male and female parts must not be plugged together when soiled.

6) 插入部件防水等级 IP68。它们不能长久置于水下使用。不要将连接器放在屋顶表面。

Waterproof degree for inserted parts is IP68. They can't be put under water for long time. Don't put the connector on the roof of surface.

7) 连接器不能承受持续的机械拉伸，电缆应该由电缆扎带固定。

The plug connection must not be subjected to continuous mechanical tension. The cable should be fixed with cable binders.

8) 产品不得在含有烃、酚、酮、氨合物等与塑料有腐蚀的环境中使用。安装过程中，禁止在连接器里添加或涂抹任何油脂及润滑剂。（见耐化学品附表）

Do not use under hydrocarbon, phenol, Ammine and plastic corrosive environment. During installation process, do not add any grease and lubricant in the connector. (See chemical resistance form)

9) 该产品应由有相应资质或经过专家培训的、具备相关安全应用规范的专业人员安装。只有在按照安装手册指定的方式组装时，连接器才被认为符合 UL 6703。如果组装或拆卸 PV-BN101A 连接器时，不按照安装手册作业，绿德将免除任何保证。

The connector is considered to be in compliance with UL 6703 only when assembled in the manner specified by assembly instructions. LEADER will be exempted from any warranty if PV-BN101A connector was assembled or disassembled without following the User Manual.



2. 技术参数 Product Specifications

连接器系统 Connector system	Φ4mm
额定电压 Rated voltage	IEC 1500V&UL 1500V
额定电流 Rated current @IEC (85℃)	25A (2.5mm ² / 14AWG) 35A (4.0mm ² / 12AWG) 40A (6.0mm ² / 10AWG)
额定脉冲电压 Rated impulse voltage	16KV
环境温度范围 Ambient temperature range	-40℃~+85℃
接触电阻 Contact resistance	≤0.25mΩ
应用等级 Application degree	Class A
防护类别 Protection class	Class II
污染等级 Pollution degree	2
防护等级 Degree of Protection	IP68 (1m, 1h) mated IP2X, unmated
阻燃等级 Flame class	UL94-V0

3. 产品选型表 Product Selection Form

PV-BN101A Max Series:系列光伏铜线连接器型号表

Connector Male Housing 连接器负极本体选型表		Connector Female Housing 连接器正极本体选型表		Male Terminal 负极导电体选型表		Female Terminal 正极导电体选型表	
TYPE 型号	Cable OD	TYPE 型号	Cable OD	TYPE 型号	Conduct Spec 导体规格	TYPE 型号	Conduct Spec 导体规格
PV-BN101A	5.6mm~7.0mm	PV-BN101A-F7 F7 型本体	5.6mm~7.0mm	PV-BN101A 型公端子	2.5mm ² ~6mm ² 14AWG~10AWG	PV-BN010A-FU U 型母端子	2.5mm ² ~6mm ² 14AWG~10AWG

4. 连接器结构及外观尺寸图 Connector Size Drawing

4.1 正极连接器 Positive Connector Housing

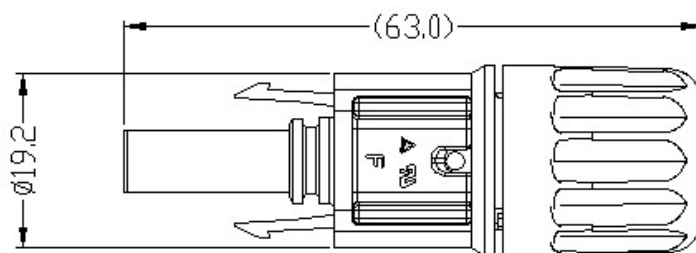

4.2 负极连接器 Negative Connector Housing

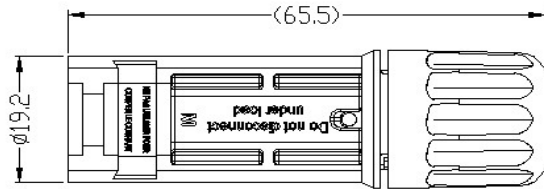

4.2 连接器 U 型端子尺寸 Type U Terminals

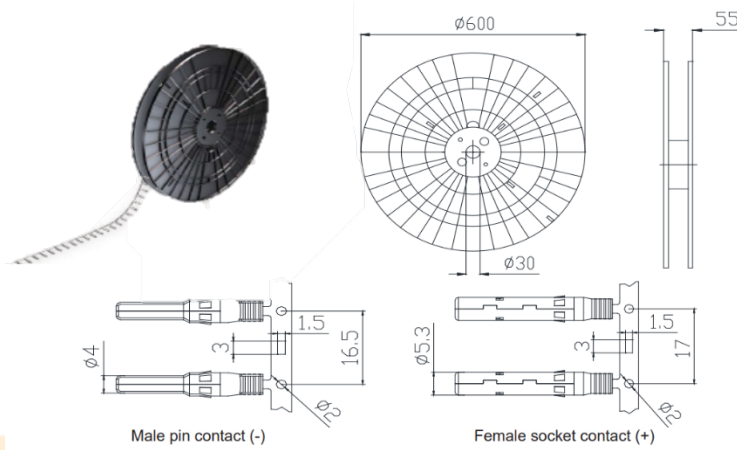

5. 组装 Assembled by machine

5.1 剥线 Stripping

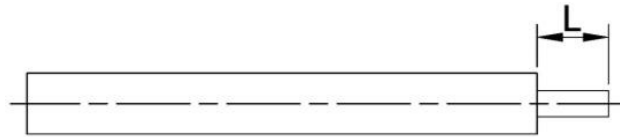

剥线尺寸 Stripping size: $6 \pm 0.5\text{mm}$

5.2 铆接 Crimping

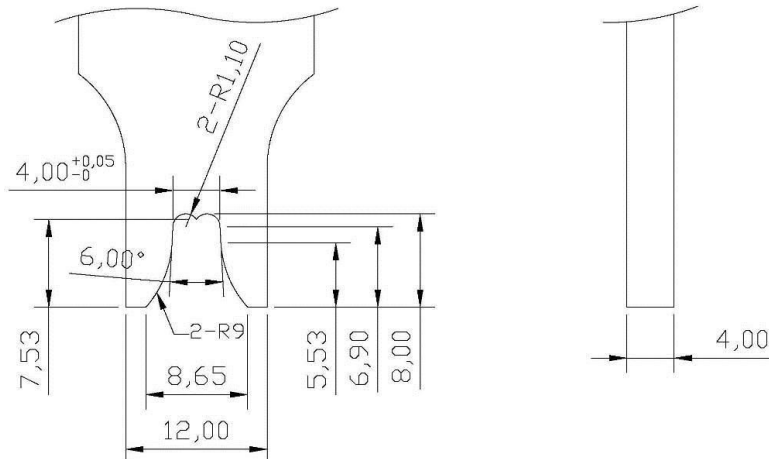

4mm²/12AWG 上刀尺寸Tool Size(Up)

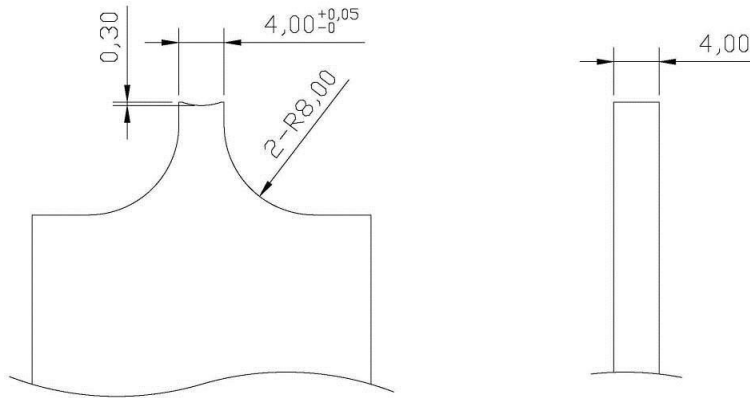

4mm²/12AWG 下刀尺寸Tool Size(Down)

典型电缆 Cable Spec	铆接高度 Crimping (H) REF	铆接宽度 Crimping (W) REF
4mm ²	2.1±0.1mm	4.1±0.1mm

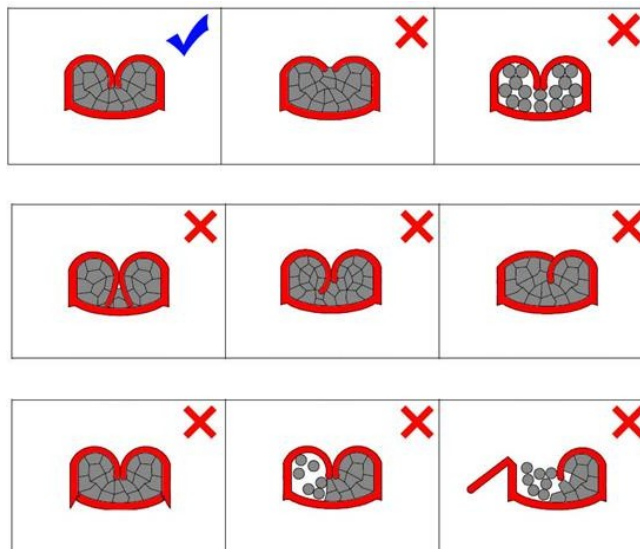
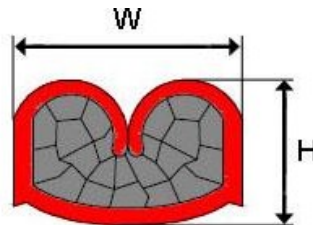

5.3 线束组装 Cable Assembly

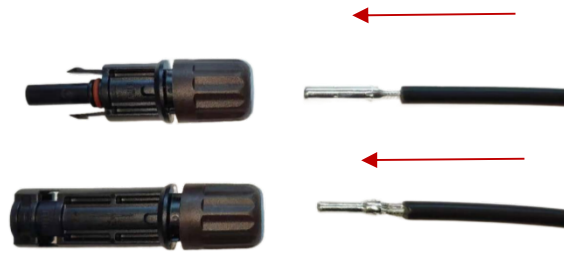

将铆接好的线束插入正极负极绝缘本体，直至金属件与本体啮合，轻轻拉动导线，检查金属件是否啮合牢固。

Push the crimped terminal into the housing until they engage. Pull lightly on the lead to check that the metal part has engaged.

5.4 螺帽组装 Nut Assembly

在锁紧连接器螺帽时，定位治具须有导正结构(治具见下图)，方可使用。

When locking the nut of the connector, the positioning fixture shall be provided with a guide structure, see below figures.

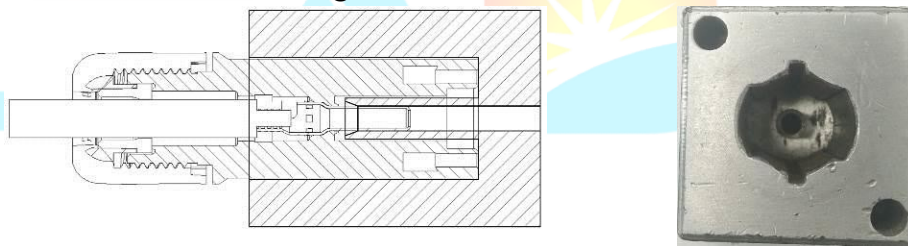

连接器型号 Connector Housing	线缆外径 Cable OD	扭力要求 Screw Force torque	螺帽参考间隙 Reference Nut Gap	备注 Remark
PV-BN101A (2.5/4/6mm ²)	5.0≤OD≤6.0 mm	3.5±0.5 N*m	0<X≤1.0 mm (REF)	操作前请校准设备的 扭力，根据扭力定间隙。 Please calibration equipment before production, define the gap by screw torque.
PV-BN101A (4/6mm ²)	5.6≤OD≤7.0 mm		0<X≤1.5 mm (REF)	
PV-BN101A (6/10mm ²)	7.0≤OD≤8.0 mm			
	8.0≤OD≤10.0 mm			



装配好后需要检查负极pin 针与负极本体的同轴度。要求圆心距 $\leq 1\text{mm}$ 。

After assembled, check the coaxiality of the negative pin and the negative body. Requirements of the center distance $\leq 1\text{mm}$.

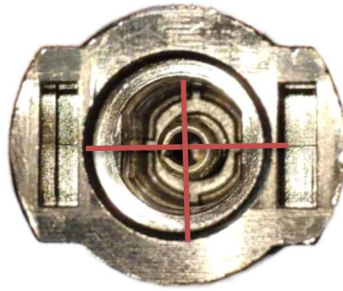

6. 人工安装 Manual Installation

6.1 工具要求 Requirements of Tools

6.1.1 剥线钳 Strip Tool



料号 P/N	钳口 Jaw	剥线范围 Strip Range	
SY-ST001	上边 Top	2.5mm ²	14AWG
	中间 Middle	4.0mm ²	12AWG
	下边 Bottom	6.0mm ²	10AWG

6.1.2 铆接钳 Crimping Tool



料号 P/N	钳口 Jaw	铆接范围 Crimping Range	
SY-CT002	上边 Top	2.5mm ²	14AWG
	中间 Middle	4.0mm ²	12AWG
	下边 Bottom	6.0mm ²	10AWG

6.1.3 塑料板手 Plastic Spanner



1套 =2片 , 料号: THB510-A;THB510-B
 1 set=2pcs, P/N: THB510-A;THB510-B

6.1.4 工具箱 Tool Box

料号 P/N	数量 Qty.	图片 Picture
Tools	1 set	



6.2 组装步骤 Assembly Steps

(1) 剥线 Stripping



剥离电缆绝缘层。Strip the insulating layer of cable. $L=6\pm 0.5\text{mm}$.

注意不要切断绝缘层下的线芯。Be attention and not to cut off the wire core.

(2) 铆接插针插套 Crimping pin and socket



首先，将金属端子放在铆接工具孔内，铆接孔朝外，调节背面的限位机构，使金属端子的最外侧边缘与铆接工具齐平。然后将剥好线的线芯插入金属端子铆接孔内，需确保所有芯线都在孔内。需保证金属件和电缆线的同轴度。最后提拉铆接工具手柄，一直按到底，完成铆接。铆接后线缆拉力参照下表。铜丝都要被包扎。

Firstly, the terminal is placed in the crimping tool jig, the jig faces outward, and the limiting mechanism of the back is adjusted so that the outermost edge of the terminal is flush with the crimping tool. Then insert the wire core into the tool's jig of the terminal, and make sure all the cores are in the hole. Ensure the coaxiality of metal parts and cables. Finally, pull the crimping tool handle and press it to the end to complete the crimping. The cable tension after crimping is referenced to the following table. All copper wires should be bandaged.



线缆规格 Cable specifications	拔出力 Cable pull-out force
4.0mm ² / 12AWG	≥312N
6.0mm ² / 10AWG	≥356N
10.0mm ² / 8AWG	≥401N
16.0mm ² / 6AWG	≥450N

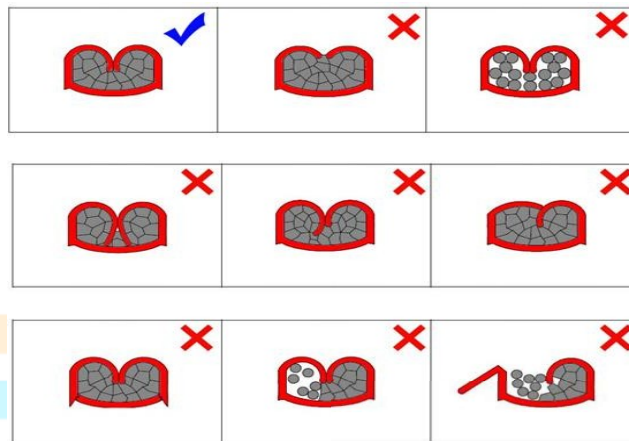

(3) 插入 Pushing

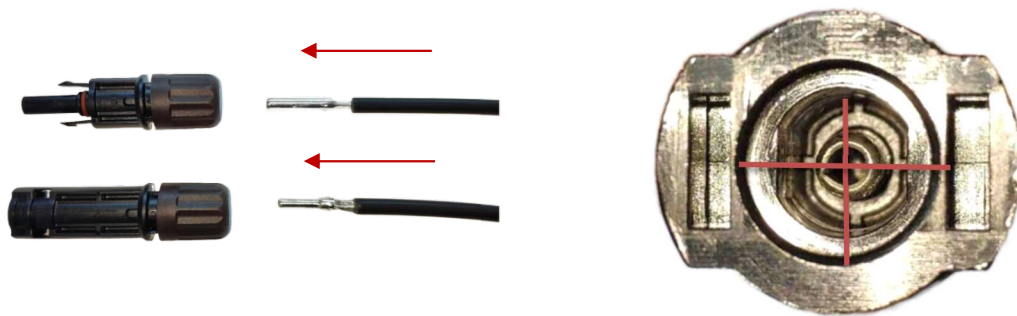

将铆接好的插头插入插座或插头的绝缘套，直至其齿合。轻轻拉动导线，检查金属件是否齿合牢固。确认负极 pin 针和负极本体同轴。

After assembled, check the coaxiality of the negative pin and the negative body. Requirements of the center distance $\leq 1\text{mm}$.



(1) 安装螺帽 Install the cable gland



先用手预拧紧，再用塑料扳手旋紧电缆螺帽。

First screw it by hands, then locktightly by plastic spanner.

型号 Type	电缆外径范围 Cable OD range	扭力要求 Screw Force torque	螺帽参考间隙 Reference Nut Gap
PV-BN10A	5.6-7.0mm	3.5±0.5 N*m	0<X≤1.5 mm (REF)

注意 1：拧螺帽时，需保证电缆线与螺帽同心。

Remark1: Ensure the concentricity of cable and cable gland when screw cable gland.

注意 2：须确认负极 pin 针和负极本体同轴，再锁紧螺帽。

Remark2: Make sure the negative pin and the negative body are coaxial and then lock the nut.

7.连接器对插及解锁 Connecting and Disconnecting

7.1 连接器对插 Connecting

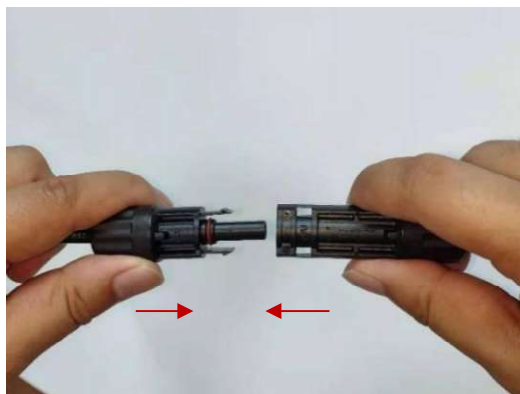

将连接器正负极对插，直到啮合。轻轻拉动，以检查是否啮合牢固。插入力≤80N。

Plug the coupling together until they engage. And pull lightly to check correct engagement. Insertion force ≤80N.



7.2 连接器解锁 Disconnecting



此插头连接，只能使用塑料板手工具解锁。

This connection can only be unlocked with plastic spanner.

8. 线缆状态 Cable Status

8.1 线缆接线 Connection of Cable

电缆根部建议保留 20mm 未折弯长度，以免因线缆折弯产生的外力引起连接器密封件变形。

In order to avoid the cable bend force lead to a visible deformation in the sealing portion of the insulation, the cable need keep at least 20mm straight length.



Wrong way for the cable



Right way for the cable

备注：请参考电缆生产商的最小弯曲半径的详细要求。

Remarks: Please refer to the detailed instruction of the min bend radius given by cable manufacturer.



8.2 接合状态 The State after Connection



9. 包装方式 Packing

9.1 散件包装 Spare Parts Packing



一般每纸箱（590*390*200mm）自封袋装500个正极连接器，自封袋装 500个负极连接器。500 个插针和 500 个插套各装一小塑料袋。

Generally, there are 500 pcs positive connector housing, 500 pcs negative connector housing, 500 pcs male terminals and the 500 pcs female terminals in one box.



10. 警告 Warning

10.1 耐化学品附表 Chemical Resistance Form

10.1.1 对产品有影响的常见化学品清单 Common Chemicals which Lead to Product Failure Easily.

化学品名 Chemical Name	测试结果 Test Result
润滑油 Lubricating oil	不兼容 Incompatible
防锈油 Rust-proof oil	不兼容 Incompatible
冲压油 Stamping oil	不兼容 Incompatible
黄油 Grease	不兼容 Incompatible
机油 Engine oil	不兼容 Incompatible
柴油 Diesel	不兼容 Incompatible
食用油 Cooking oil	不兼容 Incompatible
WD40	不兼容 Incompatible
香蕉水 Banana oil	不兼容 Incompatible
油性封孔 Oil sealing agent	不兼容 Incompatible
乙酸乙酯 Ethyl acetate	不兼容 Incompatible

备注：对于上表未列明的化学品，需经确认无影响后再使用。

Note: Chemicals which is not contained in the table should only be used after confirm it has no influence to the product.

10.2 连接器责任免除条款 The Connector Liability Exemption Clause

有违反下列情况之一者，并导致产品出问题，造成任何损失，我公司将不承担任何责任。

There exist following case, and lead to product goes wrong, any loss caused, product manufacturers will not take any responsibility.

10.2.1 产品运输和仓储 Product Transportation and Storage

1) 产品在运输、仓库过程中，不可与 10.1.1 表中有关化学品存放在一起，使产品经受这些化学品污染；

Products in the process of transportation, warehouse, cannot store with "10.1.1" in the table of chemicals together that lead the product pollution with these chemicals;

2) 产品在运输、仓库过程中，不可对产品进行过分承压、撞击等破坏产品行为；

Products in the process of transportation, warehouse, cannot pressure too much on products and such as impact damage behavior;

3) 产品在运输、仓库过程中，常温存储，应注意避光、防水、防尘等方面防护，以免降低产品性能
电站现场应特别注意；

Products in the process of transportation, warehouse, should room temperature storage, avoid light, should waterproof, dustproof, and should be paid attention to protection, so as not to reduce product performance, pay special attention to product when in power station;



4) 产品正常存储时间 1 年。

Product is recommendation finished installation in one year.

10.2.2 产品安装和使用 Product Installing and Operating

1. 产品正常工作环境温度-40~+90℃；

The product health working environment temperature - 40 ~ + 90 °C；

2. 2.2 产品现场安装，需按照本手册操作；

The Product installing should be in accordance with the Trina Solar product installation instructions；

3. 产品在沿海、沙漠等粉尘、粉尘、灰尘多的地域使用，产品出厂前必须带防尘塞；

Products in the coastal, desert dust, dust more regional use, before the products leave the factory, they must take the dust cap；

4. 产品在屋顶电站使用时，连接器不可直接放在屋顶表面。

Products used in roof power station, the connector shall not directly on the surface of the roof.

5. 产品与化学品兼容性见耐化学品附表。

Products and chemical compatibility see Chemical resistance form.

6. 连接器在未耦合情况下，产品将不能满足任何 IP 防护等级，也不能正常使用。

The connector under the condition of disconnect, the product will not be able to meet any IP protection grade, also can't normal use.

7. 产品插合后满足 IP68 防护等级要求，但不能长期置于水下或屋顶上工作。

Products meet IP68 degree of protection requirement after connects, while it can't work under water for a long time, and it can't be put on the surface of roof to avoid the strong sunlight.

8. 连接器在未对插的情况下，不可长时间放置于户外，这样可能会造成金属件腐蚀，并使连接器性能降低。

Connector in the case of disconnect, should not place in the outdoor for long time, so may be the cause of the corrosion of the metal, and lower the connector performance.

9. 连接器在户外安装、使用过程中，如果不能及时对插，请做好连接器防护工作，将连接器端口插上防尘塞，防止连接器受到水、尘等的污染，影响产品使用性能。

Connector in the process of outdoor installation and use, if not to connect in time, please do a good job in the connector protection, put on the dust cap and protect the connector from water, dust and other pollution, affect the product performance.

10. 连接器在安装、使用过程中，不可将连接器过分碰撞，拖在水中、草丛中、地上等。防止连接器使用前，内部受到污染，降低产品性能。

Connector in the process of installation and use should not be collision, drag in the water, grass, and the ground to prevent the pollution of inside the connector before use, reduce the product performance.

11. LEADER 的连接器必须与 LEADER 指定的连接器，进行正、负极对插。

Connectors of LEADER brand must be connected with connectors appointed by LEADER.



此免责声明最终解释权归东莞市绿德塑胶科技有限公司。

This disclaimer final explanation right belongs to the LEADER TECHNOLOGY SHENZHEN CO.,LTD.

东莞市绿德塑胶科技有限公司有权随时对本说明书中可能出现的打印错误，产品技术改进和创新等方面作出修改，这些改动恕不另行通知。同时各语言版本翻译的不详之处，请以中文版为准。

LEADER has the rights to make certain correction for the printing errors, improvements and innovation for the products, and there will be no prior notice when these changes happen. If there was any misunderstanding for the version in different language, please regard Chinese version as the right one.

可以在 <http://www.leader-solar.com/> 下载和打印相应的文件。

The appropriate instructions can be viewed, downloaded, and printed at www.leader-solar.com

东莞市绿德塑胶科技 LEADER TECHNOLOGY SHENZHEN CO.,LTD

No. 1 South Changqing Road, Dongguan City, Guangdong, PRC

邮编 PO No: 215555

网址 Website: <http://www.leader-solar.com/>

