

# LEADER



# LEADER

**广东绿德线缆有限公司 LEADER TECHNOLOGY(SHENZHEN)CO.,LIMITED**

营销中心地址：广东省东莞市长安镇长青南路1号8栋万科写字楼2207室

Marketing Center Address: 2207, Building 8, No. 1, Vanke Changqing South Road, Chang'an Town, Dongguan City, Guangdong Province

工厂地址：广东省东莞市谢岗镇第五工业区南外环路28号

Factory Address: No. 28, South Outer Ring Road, Fifth Industrial Zone, Xiegang Town, Dongguan City, Guangdong Province

电话 / TEL: +86-769-3335-6021 传真 / FAX: +86-769-3335-6028

电子邮箱 / E-mail: info@leadergroup-cn.com 网站 / Website: www.leadergroup-cn.com

## LEADER -Cable

Leader specializing in R&D, manufacturing and marketing PV connectors, solar cable, PV junction boxes and PV assemblies etc.

专业从事研发、制造和销售光伏连接器、光伏线缆、光伏接线盒和PV组件等。

**LEADER TECHNOLOGY(SHENZHEN)CO.,LIMITED**

**中国·东莞**  
Dongguan, China

# LEADER



# LEADER

**广东绿德线缆有限公司 LEADER TECHNOLOGY(SHENZHEN)CO.,LIMITED**

营销中心地址：广东省东莞市长安镇长青南路1号8栋万科写字楼2207室

Marketing Center Address: 2207, Building 8, No. 1, Vanke Changqing South Road, Chang'an Town, Dongguan City, Guangdong Province

工厂地址：广东省东莞市谢岗镇第五工业区南外环路28号

Factory Address: No. 28, South Outer Ring Road, Fifth Industrial Zone, Xiegang Town, Dongguan City, Guangdong Province

电话 / TEL: +86-769-3335-6021 传真 / FAX: +86-769-3335-6028

电子邮箱 / E-mail: info@leadergroup-cn.com 网站 / Website: www.leadergroup-cn.com

## LEADER -Cable

Leader specializing in R&D, manufacturing and marketing PV connectors, solar cable, PV junction boxes and PV assemblies etc.

专业从事研发、制造和销售光伏连接器、光伏线缆、光伏接线盒和PV组件等。

**LEADER TECHNOLOGY(SHENZHEN)CO.,LIMITED**

**中国·东莞**  
Dongguan, China



Low-carbon life  
低碳寿命  
Creating a better future  
创造更美好的未来

- 2 Junction Box 接线盒
- 3 Male Connector 公连接器
- 4 Female Connector 母连接器



## One stop solution for solar cable wiring systems 太阳能电缆布线系统一站式解决方案





## Quality assurance

Our products have been authorized by TUV Rhineland,UL,CE successfully.  
我们的产品已成功获得莱茵TUV、UL、CE认证。



## About LEADER

绿德光伏有限公司是一家新能源企业，位于中国东莞市长安镇，专业研发、制造和销售光伏连接器、光伏线缆、光伏接线盒和光伏组件等，集太阳能组件太阳能电器到太阳能发电系统的通离网综合利用，产品研发模具设计和开发生产为一体，销售直通车服务。凭借先进的技术，我们的产品已成功获得德国莱茵TUV、UL、CE认证。

LEADER Technology(Shenzhen)co.,Limited.is a new energy enterprise,located in Chang'an town,Dong-guan city, China specializing in R&D manufacturing and marketing PV connectors solar cable,PV junction boxes and PV assemblies etc.,with an integrated utilization from solar modules,solar energy appliance to on/off-grid solar power generation systems, and by the products R&D mold design and development production,sales through-train service. With the advanced technology,our products have been authorized by TUV Rhineland,UL,CE successfully.

LEADER坚持自主研发，严格的检测标准和完善的检测体系，现代化的管理手段和优秀的人才队伍，秉承“为卓越而生存，为创新而发展”的信念，坚持专业化、规模化、国际化，致力于使LEADER成为一流品牌。

LEADER Technology(Shenzhen)co.,Limited.is a new energy enterprise,located in Chang'an town,Dong-guan city, China specializing in R&D manufacturing and marketing PV connectors PV junction boxes and PV assemblies etc.,with an integrated utilization from solar modules,solar energy appliance to on/off-grid solar power generation systems, and by the products R&D,mold design and development production,sales through-train service. With the advanced technology,our products have been authorized by TUV Rhineland,UL,CE successfully.

Customer Satisfaction 客户满意度

Quality Foremost 质量第一

Technology Innovation 技术创新

Win-Win Situation 合作双赢





## Low-carbon life

努力减少生活方式中消耗的能量为了减少碳特别是二氧化碳排放，从而减少了大气的污染，缓解生态恶化。  
Trying to reduce the energy consumed in the lifestyle to reduce carbon, especially carbon dioxide emissions, thereby reducing the pollution of the atmosphere, mitigation of ecological deterioration.

Creating a better future



### PV Solar Cable

PAGE 01.....TUV EN50618 H1Z2Z2-K SINGLE CORE

PAGE 02.....TUV EN50618 H1Z2Z2-K DOUBLE CORE

PAGE 03.....UL 4703 SOLAR PV WIRE

PAGE 04.....EXPORT PACKING SCHEMES

### PV Connector

PAGE 05.....PV-BN101

PAGE 05.....PV-BN101A(1000V)

PAGE 05.....SY-CP4C

PAGE 06.....PV-BN101A-F6

PAGE 07.....PV-BN101A

PAGE 07.....PV-BN101B

PAGE 07.....SY-CF4C

### PV Connector

PAGE 08.....SY-CD4H

PAGE 08.....SY-CM4A-D

PAGE 09.....SY-CF0-15

PAGE 09.....SY-CF1-15

PAGE 10.....SY-CF2-15

PAGE 10.....SY-CF3-15

### PV Branch T Connector

PAGE 11.....SY-BB21-AB

PAGE 11.....SY-BB31-AB

PAGE 11.....SY-BB41-AB

PAGE 12.....SY-BB51-AB

PAGE 12.....SY-BB61-AB

### PV Branch Y Connector

PAGE 13.....SY-BY21-AB

PAGE 13.....SY-BY31-AB

PAGE 13.....SY-BY41-AB

PAGE 14.....CABLE HARNESS

### PV Junction Box

PAGE 15.....PV-BN221

PAGE 15.....PV-BN221B

PAGE 16.....PV-BN082TA-I

PAGE 16.....PV-BN126T-I

### PV Tools

PAGE 17.....PV TOOLS

PAGE 18.....PV TOOLS

# LEADER-CABLE Approvals

## SOLAR CABLE 太阳能电缆

### TUV Approved EU EN50618 Standard Solar Cable

#### Application 应用

Suitable for nominal DC voltage 1.5KV (Between conductor to conductor or conductor to earth) solar power system. 适用于标称直流电压1.5KV(导体与导体之间或导体对地)太阳能发电系统

#### Construction 结构

Conductor: Tinned copper, electrical property & Structure in accordance with EN60228 Class 5  
Insulation: LSZH electron-beam cross-linked polyolefin copolymer ROHS material, prior color black or as per customers request.  
Outer sheath: LSZH & U-resistant electron-beam cross-linked Polyolefin copolymer ROH Smaterial, prior color black or as per customer's request.

导体: 镀锡铜, 电气性能和结构符合EN60228第5类  
绝缘: LSZH电子束交联聚烯烃共聚物ROHS材料, 优先颜色为黑色或根据客户要求  
外护套: LSZH&抗u电子束交联聚烯烃共聚物ROH材料, 优先颜色黑色或根据客户的要求

#### Technical specification 技术规范

Nominal Voltage: UO/U 1.0/1.0 KV(AC) / 1.5/1.5KV (DC)  
Test Voltage: No breakdown at 6.5 KA(AC)50HZ 5min 20±5°C /15KA (DC) 5min 20±5°C  
Temperature Rating: Working Temperature -40°C ~+ 90°C, Max conductor Temperature 125°C(continuously 20h), Allowable short circuit temperature 200°C in 5 second.  
Service Life: Expected life span>25 years  
Bending Radius: Fixed installation>4D, Occasionally moved>5D

标称电压: UO/U 1.0/1.0 KV(AC) / 1.5/1.5KV (DC)  
测试电压: 6.5 KA(AC)50HZ 5min 20±5°C /15KA (DC) 5min 20±5°C  
无击穿额定温度: 工作温度-40°C ~+ 90°C, 导体最高温度125°C(连续20h), 5秒内允许短路温度200°C  
使用寿命: 预期寿命>25年  
弯曲半径: 固定安装>4D, 偶尔移动>5D



#### Material properties/Standards 材料属性/标准

Fire-resistant Performance: IEC 60332-1  
luminousness: EN50268-2  
Low Fire Load: DIN 51900  
Smoke Emission: IEC61034-1, min 60%  
Halogen Content: EN 50525-1: 2011, Appendix B  
Executive Standard: EN 50618: 2014  
耐火性能: IEC 60332-1  
透光率: EN50268-2  
低火灾负荷: DIN 51900  
烟雾排放: IEC61034-1, 最低60%  
卤素含量: EN 50525-1: 2011, 附录B  
执行标准: EN 50618: 2014

The product' detailed description please refer to the specification for approval.  
产品的详细说明请以说明书为准。



### TUV EN50618-2014 H1Z2Z2-K 1x1.5mm<sup>2</sup> ~35mm<sup>2</sup> Halogen free cable for photovoltaic equipment

Cross Section (mm <sup>2</sup> ) 标称截面	Constrction (n/mm) 导体构造	Conductor Stranded od. (mm) 绞合外径	Insulation Od (mm ± 0.15) 绝缘外径	Cable od. (mm ± 0.2) 电缆外径	Conductor Max. Rdesistance AT 20°C (Ω/km) 最大导体电阻20°C	Current Rating Ambient Temperature AT 60°C(A) 参考载流量
1x2.5	49/0.25	2.02	3.60	5.40	7.98	41
1x4.0	56/0.283	2.46	3.90	5.60	5.09	55
1x6.0	84/0.283	3.02	4.60	6.30	3.39	70
1x10	146/0.283	4.00	5.80	7.80	1.95	98
1x16	228/0.283	5.00	7.00	9.30	1.24	132
1x25	361/0.283	6.50	8.60	11.00	0.795	176
1x35	266/0.40	8.00	10.10	12.50	0.565	218

★ The current-carrying capacity is under the situation of laying the single cable in air. 载流能力是在空气中铺设单根电缆的情况下。  
★ The product' detailed description please refer to the specification for approval. 产品的详细说明请参考规范以获得批准。

# SOLAR CABLE Approvals



### TUV Approved EN50618-2014 Double Core Solar Cable

#### Application 应用

Flexible cable(wire) suitable for PV solar DC current systems. The max allowable DC voltage 1.8KV (Conductor to conductor, system without earth). Used at security level II location.  
柔性电缆(电线)适用于光伏太阳能直流系统。最大允许直流电压1.8KV(导体对导体, 无接地系统)。用于安全级别为II的位置

#### Construction 结构

Conductor: Tinned copper, electrical property & Structure in accordance with EN60228 Class 5  
Insulation: LSZH electron-beam cross-linked polyolefin copolymer ROHS material, prior color black or as per customer's request.  
Outer sheath: LSZH & U-resistant electron-beam cross-linked Polyolefin copolymer ROHS material, prior color black or as per customer's request.

导体: 镀锡铜, 电气性能和结构符合EN60228第5类  
绝缘: LSZH电子束交联聚烯烃共聚物ROHS材料, 优先颜色为黑色或根据客户要求  
外护套: LSZH &抗u电子束交联聚烯烃共聚物ROH材料, 优先颜色黑色或根据客户的要求

#### Technical specification 技术规范

Nominal Voltage: UO/U 0.6/1KV(AC)/1/1.8KV(DC)  
Test Voltage: No breakdown at 6.5 KA(AC) 50HZ 5min 20±5°C/15 KA(DC) 5min 20±5°C  
Temperature Rating: Working temperature -40°C ~+90°C Max conductor temperature 125°C(continuously 20h), Allowable shortcircuit temperature 200°C in 5 second  
Service Life: Expected life span>25 years  
Bending Radius: Fixed installation>4D, occasionally moved>5D

标称电压: UO/U 0.6/1KV(AC)/1/1.8KV(DC)  
测试电压: 6.5 KA(AC) 50HZ 5min 20±5°C/ 15ka (DC) 5min 20±5°C  
额定温度: 工作温度-40°C ~+90°C 导体最高温度125°C(连续20h), 5秒内允许短路温度200°C  
使用寿命: 预期寿命>25年  
弯曲半径: 固定安装>4D, 不定期移动>5D

#### Material properties/Standards 材料属性/标准

Fire-resistant Performance: IEC 60332-1  
Smoke emission: IEC61034-1; EN50268-2  
Low Fire Load: DIN 51900  
Halogen-free: EN 50267-2-2 PH >4.3; EN 50267-2-1  
Bromine Chloride Contents ≤0.5%; EN 60684-2, Fluorine Contents <0.1%  
Executive Standard: TUV PV1-F 2 PIG 1169/08.2007  
耐火性能: IEC61034-1; EN50268-2  
烟雾排放: IEC61034-1; EN50268-2  
低火灾负荷: DIN 51900  
无卤素: EN 50267-2-2 PH >4.3; EN 50267-2-1  
氯溴含量 ≤0.5%; EN 60684-2, 氟含量 <0.1%  
执行标准: TUV PV1-F 2 PIG 1169/08.2007

The product' detailed description please refer to the specification for approval.  
产品的详细说明请以说明书为准。

### TUV Approved EN50618-2014 H1Z2Z2-K 2x2.5mm<sup>2</sup> ~10mm<sup>2</sup> Double Core Solar Cable



Cross Section (mm <sup>2</sup> ) 标称截面	Constrction (n/mm) 导体构造	Conductor Stranded od. (mm) 绞合外径	Insulation Od (mm ± 0.15) 绝缘外径	Cable od. (mm ± 0.2) 电缆外径	Conductor Max. Rdesistance AT 20°C (Ω/km) 最大导体电阻20°C	Current Rating Ambient Temperature AT 60°C(A) 参考载流量
2x4	56/0.285	2.46	3.55	5.50x2F	5.09	55
2x6	84/0.285	3.02	4.30	6.30x2F	3.39	70
2x10	146/0.285	4.05	5.80	7.80x2F	1.95	98

★ The current-carrying capacity is under the situation of laying the single cable in air. 载流能力是在空气中铺设单根电缆的情况下。  
★ The product' detailed description please refer to the specification for approval. 产品的详细说明请参考规范以获得批准。

American Standard UL Approved Solar Cable(UL PV)

Application 应用

Mainly used in wiring of solar power system with earth or no earth  
主要用于有地或无地太阳能发电系统的接线

Construction 结构

Conductor: Stranded bare copper or tinned copper, electrical property & Structure in accordance with ASTM B33 or ASTM B172 flexible conductor requirement  
Insulation: ROHS thermosetting insulation material, prior color black or as per customer's request.  
Outer Sheath: LSZH & UV-resistant electron-beam cross-linked thermosetting Polyolefin copolymer ROHS material, prior color black or as per customer's request

导体: 绞合裸铜或镀锡铜, 电气性能和结构符合ASTM B33或ASTM B172柔性导体要求  
绝缘: ROHS热固性绝缘材料, 优先颜色黑色或根据客户要求  
外层: LSZH & 抗紫外线电子束交联热固性聚烯烃共聚物ROHS材料, 优先颜色黑色或根据客户要求

Technical specification 技术规范

Nominal Voltage: 600V(AC), 1000 V(AC), 2000 V(AC)  
Test Voltage: U=600V 18-10AWG UO=3000V 50HZ 1min 8-2AWG UO=3500V 50HZ 1min  
1-4/0AWG UO=4000V 50HZ min 1000V(AC) 2000V(AC) 18-10AWG UO=6000V 50HZ 1min  
8-2AWG UO=7500V 50HZ 1min 1-4/0AWG UO=9000V 50HZ 1min  
Temperature Rating: Working Temperature -40°C~+90°C, max conductor Temperature 125°C Allowable short circuit temperature 200°C in 5 second  
Service Life: Expected life span>25 years  
Bending Radius: Fixed installation>4D, Occasionally moved>5D

标称电压: 600V(AC), 1000v(AC), 2000v(AC)  
试验电压: U=600V 18-10AWG UO=3000V 50HZ 1min 8-2awg UO=3500V 50HZ 1min  
1-4/0AWG UO=4000V 50HZ min 1000V(AC) 2000V(AC) 18-10AWG UO=6000v 50HZ 1min  
8-2AWG UO=7500V 50Hz 1min 1-4/0AWG UO=9000V 50HZ 1min  
额定温度: 工作温度-40C~+90°C, 最高导体温度125°C允许短路温度200°C在5秒内  
使用寿命: 预期寿命>25年  
弯曲半径: 固定安装>4D, 偶尔移动>5D



Material properties/Standards 材料属性/标准

Fire-resistant Performance: UL1581 VW-1 Low-Temperature Properties: UL854  
Stability Factor: UL854 UV Resistant: UL2556 Executive Standard: UL4703  
耐火性能: UL1581 VW-1 低温性能: UL854  
稳定性系数: UL854 抗紫外线: UL2556 执行标准: UL4703

The product's detailed description please refer to the specification for approval.  
产品的详细说明请以说明书为准。



American Standard UL Approved Solar Cable(UL PV)

Size (AWG) 标称截面	Construction (n/mm) 导体构造	Conductor Stranded od. (mm) 绞合外径	Insulation Od (mm ± 0.15) 绝缘外径	Cable od. (mm ± 0.2) 电缆外径	Conductor Max. Rdesistance AT 20°C (Ω/km) 最大导体电阻20°C
12	56/0.285	2.46	4.85	5.5±0.2	5.09
10	84/0.285	3.02	5.40	6.1±0.2	3.39
8	146/0.285	4.05	6.95	7.8±0.2	2.23
6	228/0.285	5.20	8.10	9.8±0.2	1.24

★ The current-carrying capacity is under the situation of laying the single cable in air. 载流能力是在空气中铺设单根电缆的情况下。  
★ The product's detailed description please refer to the specification for approval. 产品的详细说明请参考规范以获得批准。

PACKING  
Export packing schemes



CONTAINER SIZE: 20GP (5.89M\*2.32M\*2.31M)  
CABLE SPECIFICATION: 1\*4MM2  
PACKING MODE: WOODEN TRAY + WOODEN DRUM 1000M/ROLL  
LOADING CAPACITY: 300000M

集装箱尺寸: 20 gp (5.89米\*2.32米\*2.31米)  
电缆规格: 1\*4平方毫米  
包装方式: 木托盘+木桶1000m/卷  
装载量: 300000米



CONTAINER SIZE: 20GP (5.89M\*2.32M\*2.31M)  
CABLE SPECIFICATION: 1\*6MM2  
PACKING MODE: WOODEN TRAY + WOODEN DRUM 1000M/ROLL  
LOADING CAPACITY: 240000M

集装箱尺寸: 20 gp (5.89米\*2.32米\*2.31米)  
电缆规格: 1\*6平方毫米  
包装方式: 木托盘+木桶1000m/卷  
装载量: 240000米



Wooden drum 500m  
木轴500m



Normal roll 100m/200m  
常规打卷100m/200m

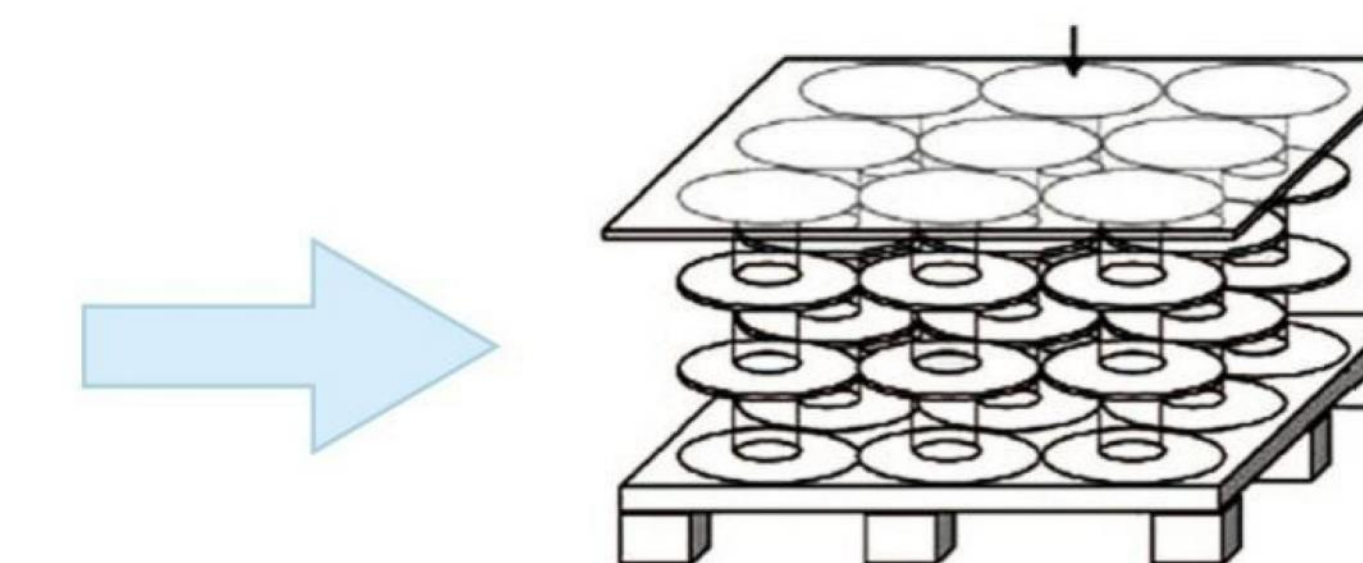

Normal drum 100m/200m  
常规打轴100m/200m



76-144 roll in one wooden case  
76-144卷装一木箱



## LEADER-Connector

PV-BN101 & PV-BN101A(1000V) & SY-CP4C

## PV Connector 连接器

### PV-BN101



#### Product Specifications 产品规格

Product No.	产品名称	PV-BN101
Rated Voltage	额定电压	TUV 1000V DC
Rating Current	额定电流	30A
Cable Spec	电线规格	2.5mm <sup>2</sup> -6.0mm <sup>2</sup> 14AWG-10AWG
Pin Dimension	端子规格	Φ4.0mm
Proof Voltage	耐电压	6000V AC(1 Min) 2200V DC(1 Min)
Pollution Degree	污染等级	2
Protection Class	防护等级	Class II
Contact Material	端子材质	Copper ,Tin Plated
Contact Resistance	接触电阻	≤ 5mΩ
Connector Material	连接器材质	PPO
Protection IP	IP保护等级	IP67(IEC 60529)
Withdrawal Force	拔出力	≥ 50N
Insertion Force	插入力	≤ 50N
Temperature Range	测试温度	-40℃~+85℃
Flame Class	阻燃等级	UL94V-0

### PV-BN101A(1000V)



#### Product Specifications 产品规格

Product No.	产品名称	PV-BN101A(1000V)
Rated Voltage	额定电压	TUV 1000V DC
Rating Current	额定电流	30A
Cable Spec	电线规格	2.5mm <sup>2</sup> -6.0mm <sup>2</sup> 14AWG-10AWG
Pin dimension	端子规格	Φ4.0mm
Proof voltage	耐电压	6000V AC(1Min) 2200V DC(1Min)
Pollution degree	污染等级	2
Protection class	防护等级	Class II
Contact Material	端子材质	Copper ,Tin Plated
Contact Resistance	接触电阻	≤ 5mΩ
Connector Material	连接器材质	PPO
Degree of Protection IP	IP保护程度	IP68(IEC 62852)
Withdrawal Force	拔出力	≥ 50N
Insertion Force	插入力	≤ 50N
Temperature Range	测试温度	-40℃~+85℃
Flame Class	阻燃等级	UL94V-0

### SY-CP4C



#### Product Specifications 产品规格

Product No.	产品名称	SY-CP4C
Rated Voltage	额定电压	TUV 1500V DC
Rating Current	额定电流	25A-50A
Cable Spec	电线规格	2.5mm <sup>2</sup> -10mm <sup>2</sup> 14AWG-8AWG
Pin dimension	端子规格	Φ4.0mm
Proof voltage	耐电压	6000V AC(1Min) 2200V DC(1Min)
Pollution degree	污染等级	2
Protection class	防护等级	Class II
Contact Material	端子材质	Copper ,Tin Plated
Contact Resistance	接触电阻	≤ 5mΩ
Connector Material	连接器材质	PPO
Degree of Protection IP	IP保护程度	IP68(IEC 62852)
Withdrawal Force	拔出力	≥ 50N
Insertion Force	插入力	≤ 50N
Temperature Range	测试温度	-40℃~+85℃
Flame Class	阻燃等级	UL94V-0

## LEADER-Connector

PV-BN101A-F6

## PV Connector 连接器

### PV-BN101A-F6



#### Product Specifications 产品规格

Product No.	产品名称	PV-BN101A-F6
Rated Voltage	额定电压	TUV 1500V DC
Rating Current	额定电流	65A
Cable Spec	电线规格	10mm <sup>2</sup> /8AWG
Pin dimension	端子规格	Φ4.0mm
Proof voltage	耐电压	6000V AC(1Min) 2200V DC(1Min)
Pollution degree	污染等级	2
Protection class	防护等级	Class II
Contact Material	端子材质	Copper ,Tin Plated
Contact Resistance	接触电阻	≤ 5mΩ
Connector Material	连接器材质	PPO
Degree of Protection IP	IP保护程度	IP68(IEC62852)
Withdrawal Force	拔出力	≥ 50N
Insertion Force	插入力	≤ 50N
Temperature Range	测试温度	-40℃~+85℃
Flame Class	阻燃等级	UL94V-0





LEADER-Connector  
PV-BN101A & PV-BN101B & SY-CF4C

PV Connector 连接器

LEADER-Connector  
SY-CD4H & SY-CM4A-D

PV-BN101A



PV-BN101B



SY-CF4C



SY-CD4H



SY-CM4A-D



Product Specifications 产品规格

Product No.	产品名称	PV-BN101A
Rated Voltage	额定电压	TUV 1500V DC
Rating Current	额定电流	30A
Cable Spec	电线规格	2.5mm <sup>2</sup> -6.0mm <sup>2</sup> 14AWG-10AWG
Pin dimension	端子规格	Φ4.0mm
Proof voltage	耐电压	6000V AC(1 Min) 2200V DC(1 Min)
Pollution degree	污染等级	2
Protection class	防护等级	Class II
Contact Material	端子材质	Copper ,Tin Plated
Contact Resistance	接触电阻	≤ 5mΩ
Connector Material	连接器材质	PPO
Degree of Protection IP	IP保护程度	IP68(IEC 62852)
Withdrawal Force	拔出力	≥ 50N
Insertion Force	插入力	≤ 50N
Temperature Range	测试温度	-40℃~+85℃
Flame Class	阻燃等级	UL94V-0

Product Specifications 产品规格

Product No.	产品名称	PV-BN101B
Rated Voltage	额定电压	TUV 1500V/UL2000V DC
Rating Current	额定电流	30A
Cable Spec	电线规格	2.5mm <sup>2</sup> -6.0mm <sup>2</sup> 14AWG-10AWG
Pin dimension	端子规格	Φ4.0mm
Proof voltage	耐电压	6000V AC(1Min) 2200V DC(1Min)
Pollution degree	污染等级	2
Protection class	防护等级	Class II
Contact Material	端子材质	Copper ,Tin Plated
Contact Resistance	接触电阻	≤ 5mΩ
Connector Material	连接器材质	PPO
Degree of Protection IP	IP保护程度	IP68(IEC 62852)
Withdrawal Force	拔出力	≥ 50N
Insertion Force	插入力	≤ 50N
Temperature Range	测试温度	-40℃~+85℃
Flame Class	阻燃等级	UL94V-0

Product Specifications 产品规格

Product No.	产品名称	SY-CF4C
Rated Voltage	额定电压	TUV 1000V
Rating Current	额定电流	3A-30A(FUSE)
Pin dimension	端子规格	Φ4.0mm
Pollution degree	污染等级	2
Protection class	防护等级	Class II
Contact Material	端子材质	Copper ,Tin Plated
Contact Resistance	接触电阻	≤ 5mΩ
Connector Material	连接器材质	PPO
Degree of Protection IP	IP保护程度	IP67(IEC 62852)
Withdrawal Force	拔出力	≥ 50N
Insertion Force	插入力	≤ 50N
Temperature Range	测试温度	-40℃~+85℃
Flame Class	阻燃等级	UL94V-0

Product Specifications 产品规格

Product No.	产品名称	SY-CD4H
Rated Voltage	额定电压	TUV 1000V DC
Rating Current	额定电流	15A-30A(DIODE)
Pin dimension	端子规格	Φ4.0mm
Pollution degree	污染等级	2
Protection class	防护等级	Class II
Contact Material	端子材质	Copper ,Tin Plated
Contact Resistance	接触电阻	≤ 5mΩ
Connector Material	连接器材质	PPO
Degree of Protection IP	IP保护程度	IP67(IEC 62852)
Withdrawal Force	拔出力	≥ 50N
Insertion Force	插入力	≤ 50N
Temperature Range	测试温度	-40℃~+85℃
Flame Class	阻燃等级	UL94V-0

Product Specifications 产品规格

Product No.	产品名称	SY-CM4A-D
Rated Voltage	额定电压	TUV 1000V DC
Rating Current	额定电流	15A
Pin dimension	端子规格	Φ4.0mm
Pollution degree	污染等级	2
Protection class	防护等级	Class II
Contact Material	端子材质	Copper ,Tin Plated
Contact Resistance	接触电阻	≤ 5mΩ
Connector Material	连接器材质	PPO
Degree of Protection IP	IP保护程度	IP67(IEC 62852)
Withdrawal Force	拔出力	≥ 50N
Insertion Force	插入力	≤ 50N
Temperature Range	测试温度	-40℃~+85℃
Flame Class	阻燃等级	UL94V-0

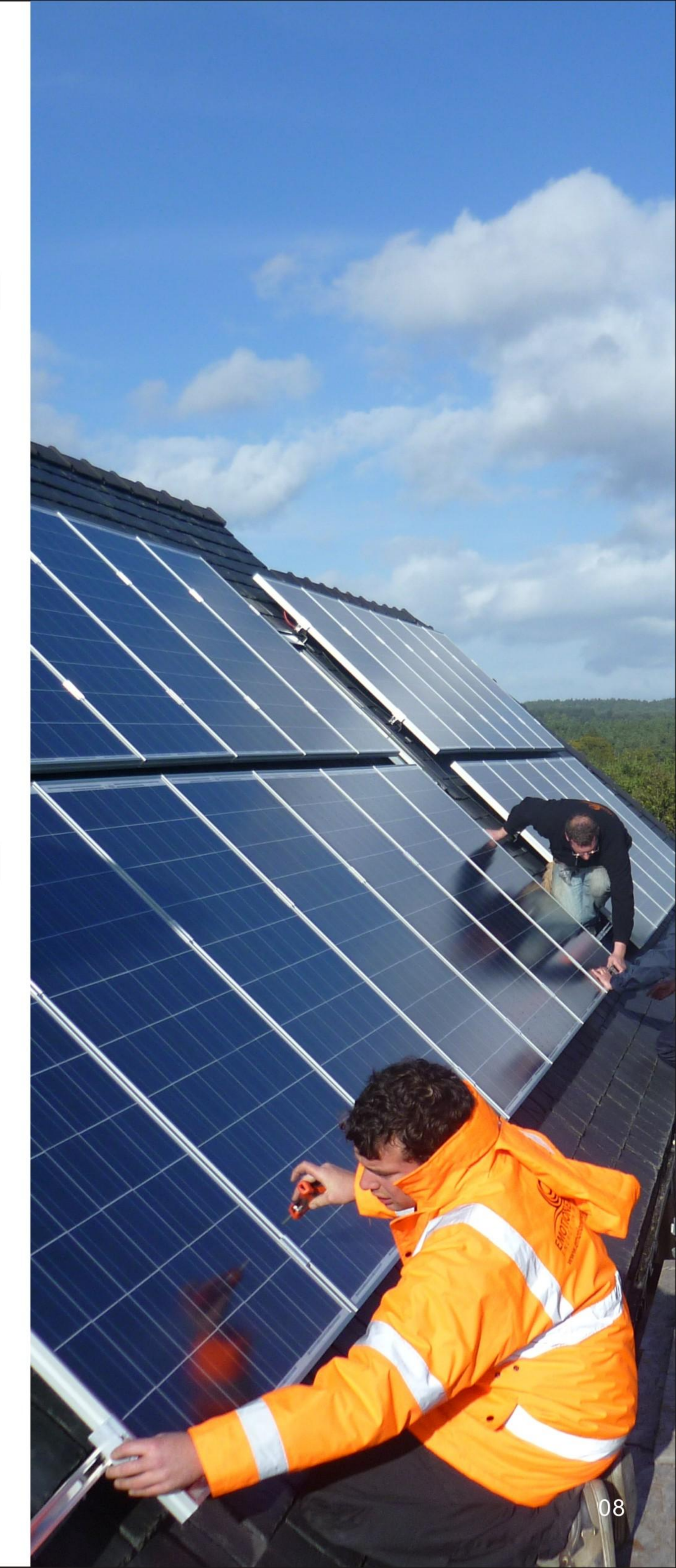

## LEADER-Connector SY-CF0-15 & SY-CF1-15

### SY-CF0-15



#### Product Specifications 产品规格

Product No.	产品名称	SY-CF0-15
Rated Voltage	额定电压	TUV 1500V DC
Rating Current	额定电流	3A-50A (FUSE)
Pin dimension	端子规格	Φ4.0mm
Pollution degree	污染等级	2
Protection class	防护等级	Class II
Contact Material	端子材质	Copper, Tin plated
Contact Resistance	接触电阻	≤ 5mΩ
Connector Material	连接器材质	PPO
Degree of Protection IP	IP保护程度	IP68(IEC 62852)
Withdrawal Force	拔出力	≥ 50N
Insertion Force	插入力	≤ 50N
Temperature Range	测试温度	-40℃~+85℃
Flame Class	阻燃等级	UL94V-0

### SY-CF1-15



#### Product Specifications 产品规格

Product No.	产品名称	SY-CF1-15
Rated Voltage	额定电压	TUV 1500V DC
Rating Current	额定电流	3A-50A (FUSE)
Pin dimension	端子规格	Φ4.0mm
Pollution degree	污染等级	2
Protection class	防护等级	Class II
Contact Material	端子材质	Copper, Tin plated
Contact Resistance	接触电阻	≤ 5mΩ
Connector Material	连接器材质	PPO
Degree of Protection IP	IP保护程度	IP68(IEC 62852)
Withdrawal Force	拔出力	≥ 50N
Insertion Force	插入力	≤ 50N
Temperature Range	测试温度	-40℃~+85℃
Flame Class	阻燃等级	UL94V-0



## LEADER-Connector SY-CF2-15 & SY-CF3-15

### SY-CF2-15



#### Product Specifications 产品规格

Product No.	产品名称	SY-CF2-15
Rated Voltage	额定电压	TUV 1500V DC
Rating Current	额定电流	3A-50A (FUSE)
Pin dimension	端子规格	Φ4.0mm
Pollution degree	污染等级	2
Protection class	防护等级	Class II
Contact Material	端子材质	Copper, Tin plated
Contact Resistance	接触电阻	≤ 5mΩ
Connector Material	连接器材质	PPO
Degree of Protection IP	IP保护程度	IP68(IEC 62852)
Withdrawal Force	拔出力	≥ 50N
Insertion Force	插入力	≤ 50N
Temperature Range	测试温度	-40℃~+85℃
Flame Class	阻燃等级	UL94V-0

### SY-CF3-15



#### Product Specifications 产品规格

Product No.	产品名称	SY-CF3-15
Rated Voltage	额定电压	TUV 1500V DC
Rating Current	额定电流	3A-50A (FUSE)
Pin dimension	端子规格	Φ4.0mm
Pollution degree	污染等级	2
Protection class	防护等级	Class II
Contact Material	端子材质	Copper, Tin plated
Contact Resistance	接触电阻	≤ 5mΩ
Connector Material	连接器材质	PPO
Degree of Protection IP	IP保护程度	IP68(IEC 62852)
Withdrawal Force	拔出力	≥ 50N
Insertion Force	插入力	≤ 50N
Temperature Range	测试温度	-40℃~+85℃
Flame Class	阻燃等级	UL94V-0



## LEADER-T Branch Connector

SY-BB21-AB & SY-BB31-AB & SY-BB41-AB

SY-BB21-AB



SY-BB31-AB



SY-BB41-AB



### Product Specifications 产品规格

Product No.	产品名称	SY-BB21-AB
Rated Voltage	额定电压	TUV 1500V
Rating Current	额定电流	50A
Cable Spec	电线规格	2.5mm <sup>2</sup> -6.0mm <sup>2</sup> 14AWG-10AWG
Pin dimension	端子规格	Φ4.0mm
Proof voltage	耐电压	6000V AC(1Min) 2200V DC(1Min)
Pollution degree	污染等级	2
Protection class	防护等级	Class II
Contact Material	端子材质	Copper ,Tin Plated
Contact Resistance	接触电阻	≤ 5mΩ
Connector Material	连接器材质	PPO
Degree of Protection IP	IP保护程度	IP67(IEC 62852)
Withdrawal Force	拔出力	≥ 50N
Insertion Force	插入力	≤ 50N
Temperature Range	测试温度	-40℃~+85℃
Flame Class	阻燃等级	UL94V-0

### Product Specifications 产品规格

Product No.	产品名称	SY-BB31-AB
Rated Voltage	额定电压	TUV 1000V
Rating Current	额定电流	50A
Cable Spec	电线规格	2.5mm <sup>2</sup> -6.0mm <sup>2</sup> 14AWG-10AWG
Pin dimension	端子规格	Φ4.0mm
Proof voltage	耐电压	6000V AC(1Min) 2200V DC(1Min)
Pollution degree	污染等级	2
Protection class	防护等级	Class II
Contact Material	端子材质	Copper ,Tin Plated
Contact Resistance	接触电阻	≤ 5mΩ
Connector Material	连接器材质	PPO
Degree of Protection IP	IP保护程度	IP67(IEC 60529)
Withdrawal Force	拔出力	≥ 50N
Insertion Force	插入力	≤ 50N
Temperature Range	测试温度	-40℃~+85℃
Flame Class	阻燃等级	UL94V-0

### Product Specifications 产品规格

Product No.	产品名称	SY-BB41-AB
Rated Voltage	额定电压	TUV 1000V
Rating Current	额定电流	50A
Cable Spec	电线规格	2.5mm <sup>2</sup> -6.0mm <sup>2</sup> 14AWG-10AWG
Pin dimension	端子规格	Φ4.0mm
Proof voltage	耐电压	6000V AC(1Min) 2200V DC(1Min)
Pollution degree	污染等级	2
Protection class	防护等级	Class II
Contact Material	端子材质	Copper ,Tin Plated
Contact Resistance	接触电阻	≤ 5mΩ
Connector Material	连接器材质	PPO
Degree of Protection IP	IP保护程度	IP67(IEC 60529)
Withdrawal Force	拔出力	≥ 50N
Insertion Force	插入力	≤ 50N
Temperature Range	测试温度	-40℃~+85℃
Flame Class	阻燃等级	UL94V-0

## LEADER-T Branch Connector

SY-BB51-AB & SY-BB61-AB

SY-BB51-AB



SY-BB61-AB



### Product Specifications 产品规格

Product No.	产品名称	SY-BB51-AB
Rated Voltage	额定电压	TUV 1000V
Rating Current	额定电流	50A
Cable Spec	电线规格	2.5mm <sup>2</sup> -6.0mm <sup>2</sup> 14AWG-10AWG
Pin dimension	端子规格	Φ4.0mm
Proof voltage	耐电压	6000V AC(1Min) 2200V DC(1Min)
Pollution degree	污染等级	2
Protection class	防护等级	Class II
Contact Material	端子材质	Copper ,Tin Plated
Contact Resistance	接触电阻	≤ 5mΩ
Connector Material	连接器材质	PPO
Degree of Protection IP	IP保护程度	IP67(IEC 60529)
Withdrawal Force	拔出力	≥ 50N
Insertion Force	插入力	≤ 50N
Temperature Range	测试温度	-40℃~+85℃
Flame Class	阻燃等级	UL94V-0

### Product Specifications 产品规格

Product No.	产品名称	SY-BB61-AB
Rated Voltage	额定电压	TUV 1000V
Rating Current	额定电流	50A
Cable Spec	电线规格	2.5mm <sup>2</sup> -6.0mm <sup>2</sup> 14AWG-10AWG
Pin dimension	端子规格	Φ4.0mm
Proof voltage	耐电压	6000V AC(1Min) 2200V DC(1Min)
Pollution degree	污染等级	2
Protection class	防护等级	Class II
Contact Material	端子材质	Copper ,Tin Plated
Contact Resistance	接触电阻	≤ 5mΩ
Connector Material	连接器材质	PPO
Degree of Protection IP	IP保护程度	IP67(IEC 60529)
Withdrawal Force	拔出力	≥ 50N
Insertion Force	插入力	≤ 50N
Temperature Range	测试温度	-40℃~+85℃
Flame Class	阻燃等级	UL94V-0



## LEADER-Junction Box

PV-BN221 & PV-BN221B & PV-BN082TA-I

### PV-BN221



#### Product Specifications 产品规格

Product No.	产品名称	PV-BN221
Rated Voltage	额定电压	TUV 1000V DC
Busar connection	焊带链接	Welding
Rating Current	额定电流	4.8A-10A
Cable Spec	电线规格	2.5mm <sup>2</sup> -6.0mm <sup>2</sup> 14AWG-10AWG
Degree of protection	防水方式	Pouring sealant
Proof voltage	耐电压	6000V AC(1Min) 2200V DC(1Min)
Amount of rails	轨道数量	2 rail terminals
Protection class	防护等级	Class II
Contact Material	端子材质	Copper ,Tin Plated
Contact Resistance	接触电阻	≤ 5mΩ
BOX Material	盒子材料	PPO
Degree of Protection IP	IP保护程度	IP67(IEC 60529)
Temperature Range	测试温度	-40℃~+85℃
Flame Class	阻燃等级	UL94V-0

### PV-BN221B



#### Product Specifications 产品规格

Product No.	产品名称	PV-BN221B
Rated Voltage	额定电压	TUV 1000V DC
Busar connection	焊带链接	Welding
Rating Current	额定电流	8.4A-15A
Cable Spec	电线规格	4.0mm <sup>2</sup> /12AWG
Degree of protection	防水方式	Pouring sealant
Proof voltage	耐电压	6000V AC(1Min) 2200V DC(1Min)
Amount of rails	轨道数量	2 rail terminals
Protection class	防护等级	Class II
Contact Material	端子材质	Copper ,Tin Plated
Contact Resistance	接触电阻	≤ 5mΩ
BOX Material	盒子材料	PPO
Degree of Protection IP	IP保护程度	IP67(IEC 60529)
Temperature Range	测试温度	-40℃~+85℃
Flame Class	阻燃等级	UL94V-0

### PV-BN082TA-I



#### Product Specifications 产品规格

Product No.	产品名称	PV-BN082TA-I
Rated Voltage	额定电压	TUV 1500V DC
Busar connection	焊带链接	Welding
Rating Current	额定电流	15A
Cable Spec	电线规格	4.0mm <sup>2</sup> -6.0mm <sup>2</sup> 12AWG-10AWG
Degree of protection	防水方式	Sealing ring
Proof voltage	耐电压	6000V AC(1Min) 2200V DC(1Min)
Amount of rails	轨道数量	4 rail terminals
Protection class	防护等级	Class II
Contact Material	端子材质	Copper ,Tin Plated
Contact Resistance	接触电阻	≤ 5mΩ
BOX Material	盒子材料	PPO
Degree of Protection IP	IP保护程度	IP67(IEC 60529)
Temperature Range	测试温度	-40℃~+85℃
Flame Class	阻燃等级	UL94V-0

## LEADER-Junction Box

PV-BN126T-I

### PV-BN126T-I



#### Product Specifications 产品规格

Product No.	产品名称	PV-BN126T-I
Rated Voltage	额定电压	TUV 1500V DC
Busar connection	焊带链接	Welding
Rating Current	额定电流	14A
Cable Spec	电线规格	4.0mm <sup>2</sup> -6.0mm <sup>2</sup> 12AWG-10AWG
Degree of protection	防水方式	Pouring sealant
Proof voltage	耐电压	6000V AC(1Min) 2200V DC(1Min)
Amount of rails	轨道数量	4 rail terminals
Protection class	防护等级	Class II
Contact Material	端子材质	Copper ,Tin Plated
Contact Resistance	接触电阻	≤ 5mΩ
BOX Material	盒子材料	PPO
Degree of Protection IP	IP保护程度	IP67(IEC 60529)
Temperature Range	测试温度	-40℃~+85℃
Flame Class	阻燃等级	UL94V-0



## LEADER-Y Branch Connector

SY-BY21-AB & SY-BY31-AB & SY-BY41-AB

SY-BY21-AB



SY-BY31-AB

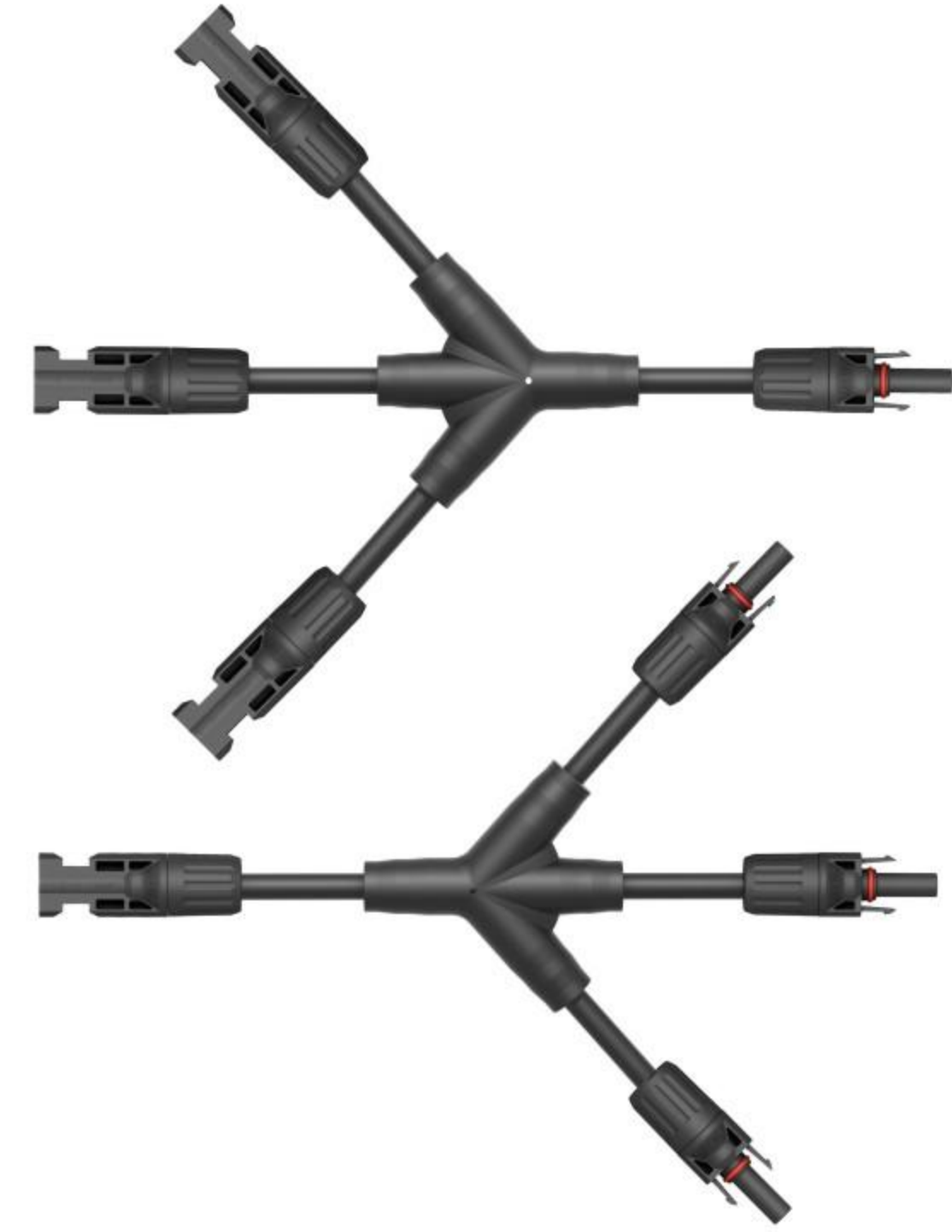

SY-BY41-AB



### Product Specifications 产品规格

Product No.	产品名称	SY-BY21-AB
Rated Voltage	额定电压	TUV 1000V
Rating Current	额定电流	20A~30A
Cable Spec	电线规格	2.5mm <sup>2</sup> -6.0mm <sup>2</sup> 14AWG-10AWG
Pin dimension	端子规格	Φ4.0mm
Pollution degree	污染等级	2
Protection class	防护等级	Class II
Contact Material	端子材质	Copper ,Tin Plated
Contact Resistance	接触电阻	≤ 5mΩ
Connector Material	盒子材料	PP
Degree of Protection IP	IP保护程度	IP67(IEC 60529)
Withdrawal Force	拔出力	≥ 50N
Insertion Force	插入力	≤ 50N
Temperature Range	测试温度	-40℃~+85℃
Flame Class	阻燃等级	UL94V-0

### Product Specifications 产品规格

Product No.	产品名称	SY-BY31-AB
Rated Voltage	额定电压	TUV 1000V
Rating Current	额定电流	20A~30A
Cable Spec	电线规格	2.5mm <sup>2</sup> -6.0mm <sup>2</sup> 14AWG-10AWG
Pin dimension	端子规格	Φ4.0mm
Pollution degree	污染等级	2
Protection class	防护等级	Class II
Contact Material	端子材质	Copper ,Tin Plated
Contact Resistance	接触电阻	≤ 5mΩ
Connector Material	盒子材料	PP
Degree of Protection IP	IP保护程度	IP67(IEC 60529)
Withdrawal Force	拔出力	≥ 50N
Insertion Force	插入力	≤ 50N
Temperature Range	测试温度	-40℃~+85℃
Flame Class	阻燃等级	UL94V-0

### Product Specifications 产品规格

Product No.	产品名称	SY-BY41-AB
Rated Voltage	额定电压	TUV 1000V
Rating Current	额定电流	20A~30A
Cable Spec	电线规格	2.5mm <sup>2</sup> -6.0mm <sup>2</sup> 14AWG-10AWG
Pin dimension	端子规格	Φ4.0mm
Pollution degree	污染等级	2
Protection class	防护等级	Class II
Contact Material	端子材质	Copper ,Tin Plated
Contact Resistance	接触电阻	≤ 5mΩ
Connector Material	盒子材料	PP
Degree of Protection IP	IP保护程度	IP67(IEC 60529)
Withdrawal Force	拔出力	≥ 50N
Insertion Force	插入力	≤ 50N
Temperature Range	测试温度	-40℃~+85℃
Flame Class	阻燃等级	UL94V-0

## LEADER-Harness

CABLE HARNESS

CABLE HARNESS

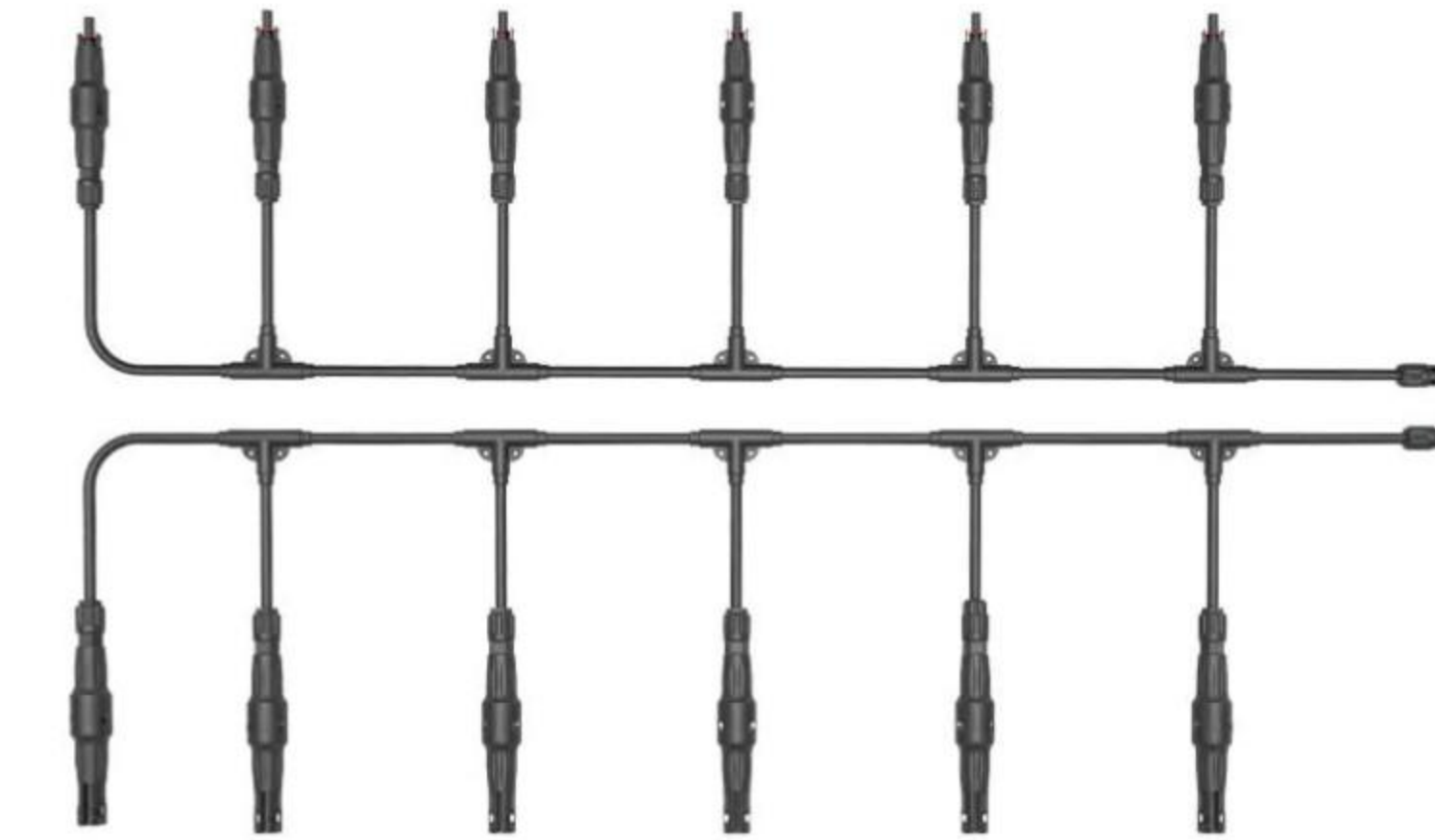

### Product Specifications 产品规格

Product No.	产品名称	CABLE HARNESS
Rated Voltage	额定电压	TUV 1500V DC/UL 1000V DC
Rating Current	额定电流	20A~30A
Cable Spec	电线规格	2.5mm <sup>2</sup> -6.0mm <sup>2</sup> 14AWG-10AWG
Pin dimension	端子规格	Φ4.0mm
Pollution degree	污染等级	2
Protection class	防护等级	Class II
Contact Material	端子材质	Copper ,Tin Plated
Contact Resistance	接触电阻	≤ 5mΩ
Connector Material	盒子材料	PP
Degree of Protection IP	IP保护程度	IP67(IEC 60529)
Withdrawal Force	拔出力	≥ 50N
Insertion Force	插入力	≤ 50N
Temperature Range	测试温度	-40℃~+85℃
Flame Class	阻燃等级	UL94V-0



# PV TOOLS

SY-T001/002 & SY-C005/006

## Product Specifications 产品规格

Product No. SY-T001/SY-T002

Suitable For Locking turncap and unlocking 4.0/2.0 connectors



OPEN-END SPANNER AND UNLOCKING TOOL(1500V)  
开口扳手及解锁工具(1500v)



SEALING CAPS Mc4  
密封帽 Mc4



OPEN-END SPANNER AND UNLOCKING TOOL(1000V)  
开口扳手及开锁工具(1000v)

# PV TOOLS

SY-C003A/B/C & SY-S004

# LEADER

CRIMPING PLIERS 1 压线钳



CUTTING TOOL 剪切工具



CRIMPING PLIERS 2 压线钳



MC4 TOOL CASE 1 MC4工具箱



WIRE STRIPPER PLIER 剥线钳



MC4 TOOL CASE 2 MC4工具箱

